

ARROYITO HEAVY WATER PRODUCTION PLANT, ARGENTINA

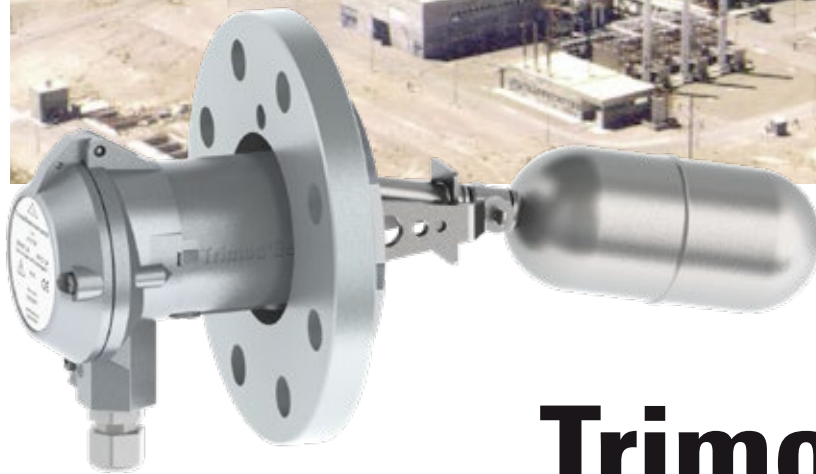

Trimod Besta

Level measurement A brand of Bachofen AG
www.trimodbesta.com



ClassNK



IEC 61508/61511

The Plant

The Industrial Heavy Water Plant (PIAP), located at Arroyito (Province of Neuquén) is classified as a high-technology plant among conventional chemical industries. Its production capacity amounts to 200 tons per year and is split into two production lines of 100 tons each. The process selected and applied by the PIAP for obtaining heavy water is based on a method known as «Monothermal Ammonia-Hydrogen Isotopic exchange».

The electromechanic equipment plus the structures weigh more than 27'000 tons and include, among others 250 heat exchangers, 240 pressure vessels, 90 gas compressors, 13 reactors, 30 distillation columns

Additionally, the PIAP contains two ammonia-synthesis reactors, each one of them with a production capacity of 2150 tons per day. These synthesis units are the largest in the world and are currently used in a closed circuit for obtaining virgin heavy water.

The technical characteristics of the synthesis reactors and the possibility of producing ammonia and fertilizers at an industrial scale, either individually or along with the production of heavy water, have generated appeal for both domestic and international investments in the Patagonian region.



Source:
www.ensi.com.ar/docs/heavywater/i-fr-aguapesada.html

Requirement for level switches

- Operating pressure up to 261 bar (cl. 2500)
- Operating temperature To max. 221°C
- Intrinsically safe circuits for zone 1 and 2
- Gold plated microswitch contacts
- Float chamber: cold hydraulic pressure test at 420 bar
- Float chamber: helium leakage test

Float chamber test conditions

- Charpy-V at -30°C
- NDT test at -40°C (Pellini)
- All welding edges 100% PT
- Post weld heat treatments 620°C
- 100% PT test surface
- Cold hydraulic pressure test (cl. 2500: 420 bar)
- Helium leakage test

Installed level switch types

Bachofen has delivered 96 units of level switches and float chambers. Switch types

- | | | |
|---------------------|------------------------|-------|
| ▪ 42 x DB 132R 07 | ANSI cl. 300, To max. | 80°C |
| ▪ 6 x HB 132R 07 | ANSI cl. 300, To max. | 221°C |
| ▪ 32 x DB 136RS 032 | ANSI cl. 1500, To max. | 65°C |
| ▪ 16 x DB 137JS 032 | ANSI cl. 2500, To max. | 120°C |

Industrial range version with ANSI flanges. Picture shows similar switch type and float chambers as supplied.

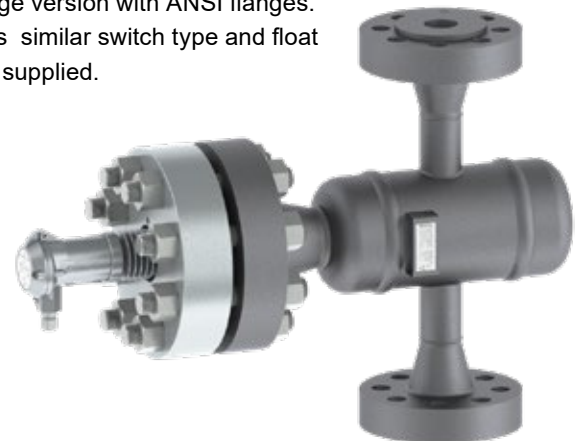

Why Trimod´Besta?

Bachofen was the only supplier who was able to offer explosion proof switches and float chambers acc. to ANSI cl. 2500 and had the knowledge to manufacture and to test the float chambers acc. to the customers specification.