

Top mounted level switches for level alarm or pump control applications

Nominal pressure	PN 16 max. 16 bar to 300°C
Operating temperature	0 to 300°C
Ambient temperature	0 to 70°C
Density of the liquid	
> Pump control	min. 0.5 kg/dm ³
> Alarm	min. 0.5 kg/dm ³
Operating differential	12 to 4340 mm
Wetside material	stainless steel (CrNiMo)
Housing material	seawater resistant die cast aluminium
Flange dimensions	square 92 x 92 mm, PCD 92 mm
Switch element	Microswitch SPDT with silver contacts
Switch rating	250 VAC, 5 A / 30 VDC, 5 A
Enclosure	IP65
Weight	approx. 3.0 kg
Safety Integrity Level (SIL)	SIL 1

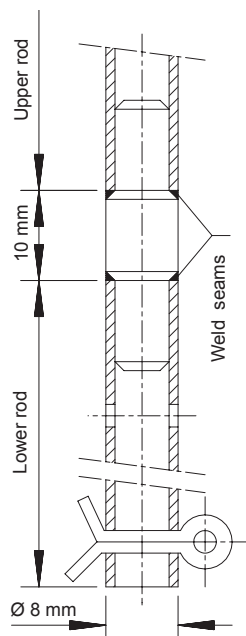
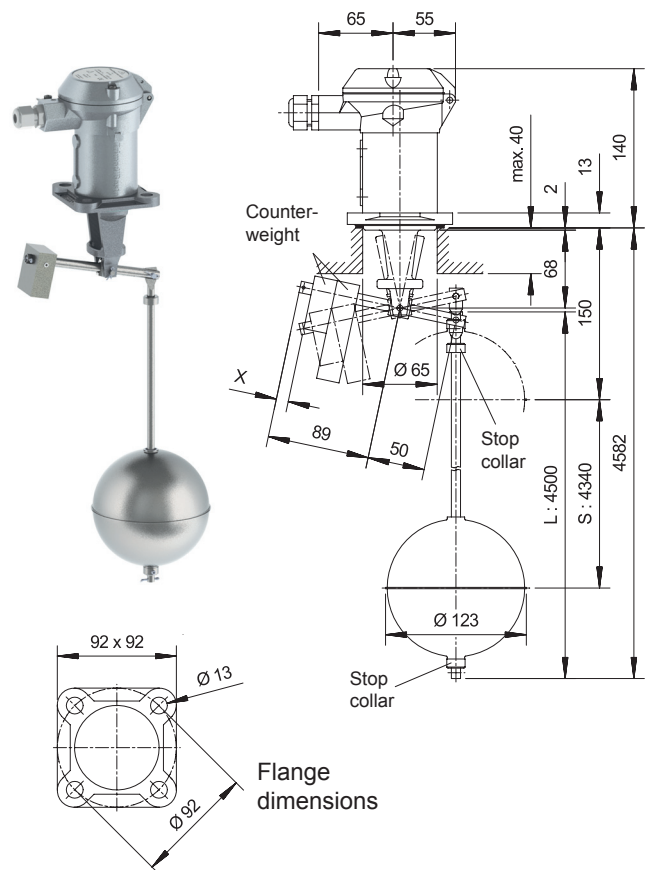
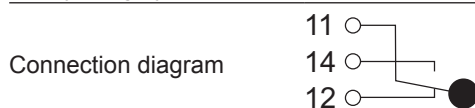

Vertical rods

Both rods and the supplied nipple (L = 10 mm) have to be welded together as shown. Both weld seams must be smoothed, so the float can glide freely.

Installation

Over open tanks or sumps on a bracket. On closed tanks on the manhole cover with the float mounted from the inside. In the absence of a manhole, i.e. the float can not be mounted from the inside, an intermediate flange with an inside diameter of min. 125 mm of flange modules acc. to EN/DIN DN125 or ANSI DN5" should be used. We recommend, that the rod should be guided loosely at the lower end.

Setting the switching differential

1. For pump control (2 switch points)

The required differential is set by fixing the two stop collars in the appropriate positions on the rod. The counterweight has to be adjusted to compensate for the rod weight (without float), until the cross arm is balanced. The float slides up and down the rod with the liquid level and actuates the switch at the set position of the stop collars.

The switch remains latched between the two positions, which are for applications such as pump control where the contactor coil would need to remain energized throughout the pumping cycle.

2. For alarm operation (1 switch point)

Only the lower collar is fixed on the rod (below the float). Within the limit of the rod length, the height of the alarm point can be chosen as required. The counterweight has to be set, to outweigh the rod (without float). The alarm switching differential is 12 mm.



Quality Assurance

- Bachofen AG is certified acc. to ISO 9001.

Certificates

- Material certificates acc. to EN 10204-2.2 and EN 10204 3.1
- Test records of hydraulic pressure tests and functional tests

Options

- Dual SPDT microswitches (SIL 2)
- Microswitches with gold plated contacts
- Self checking proximity switches acc. to NAMUR
- Enclosure IP67, or IP68 for submersible applications
- 380 VAC, 5 A 440 VDC, 0.3 A (type: AE26)
- Pneumatic switches ON/OFF
- High and low temperature versions
- Cable entry with 3/4" NPT internal thread
- Switch housing:
 - chromated
 - stainless steel (CrNiMo)
 - epoxy painted
- Flange modules: - acc. to ANSI, EN/DIN, BS & JIS

Marine approvals and registrations of Trimod Besta level switches



Counterflanges

The simplest method of installing the Trimod Besta level switch type A 01 142 is to use the standard weld-on counterflanges. These are available in carbon steel (P250GH) and in stainless steel (1.4401). If the float can be mounted from the inside, the counterflange can be welded directly to the tank. Otherwise the counterflange has to be welded to an intermediate flange (I.D. min. 125 mm).

Temperature range:

Material P250GH -10 to 300°C
 Material 1.4401: -196 to 400°C

Type	Specification	Flange-material	Stud-material
2829.1	Counterflange	P250GH	5.8
2831.3	Counterflange	1.4401	A2

