

Besta AG
Ackerstrasse 45
CH-8610 Uster
Switzerland
Phone +41 43 399 15 15
Fax +41 43 399 15 00
info@besta.ch
www.besta.ch



Trimod Besta Safety Manual V2.0

Trimod Besta Level Switches

Besta AG

Version V2.0, March 2014

The document was prepared using best effort. The authors make no warranty of any kind and shall not be liable in any event for incidental or consequential damages in connection with the application of the document.

Content

1	Introduction	3
1.1	Terms and Abbreviations	3
1.2	Acronyms	3
1.3	Product Support.....	4
1.4	Related Literature	4
1.5	Reference Standards.....	4
2	Product Description.....	5
3	Application Examples	6
4	Available Certificates.....	6
5	Ordering Information	7
6	Designing a SIF using a Trimod Besta level switch	7
6.1	Safety Function.....	7
6.2	Environmental Limits	7
6.3	Application Limits.....	7
6.4	Design Verification.....	7
6.5	SIL Capability	8
6.5.1	Systematic Integrity.....	8
6.5.2	Random Integrity.....	8
6.5.3	Safety Parameters	8
6.6	Connection of the Trimod Besta level switch to the SIS Logic-solver	10
6.7	General Requirements.....	10
7	Installation and Maintenance.....	10
7.1	Installation and Commissioning	10
7.2	Physical Location and Placement	10
8	Operation and Maintenance	11
8.1	Proof Test without automatic testing	11
8.2	Repair and Replacement	11
8.3	Useful Life	11
8.4	Besta AG Notification.....	11

1 Introduction

This Safety Manual provides information necessary to design, install, verify and maintain a Safety Instrumented Function (SIF) utilizing the Trimod Besta level switch. This manual provides necessary requirements for meeting the IEC 61508 or IEC 61511 functional safety standards.

1.1 Terms and Abbreviations

Safety	Freedom from unacceptable risk of harm
Functional Safety	The ability of a system to carry out the actions necessary to achieve or to maintain a defined safe state for the equipment / machinery / plant / apparatus under control of the system
Basic Safety	The equipment must be designed and manufactured such that it protects against risk of damage to persons by electrical shock and other hazards and against resulting fire and explosion. The protection must be effective under all conditions of the nominal operation and under single fault condition
Safety Assessment	The investigation to arrive at a judgment - based on evidence - of the safety achieved by safety-related systems
Fail-Safe State	State where the micro-switch is de-energized.
Fail Safe	Failure that causes the switch to go to the defined fail-safe state without a demand from the process.
Fail Dangerous	Failure that does not respond to a demand from the process (i.e. being unable to go to the defined fail-safe state).
Fail Dangerous Undetected	Failure that is dangerous and that is not being diagnosed by automatic stroke testing.
Fail Annunciation Undetected	Failure that does not cause a false trip or prevent the safety function but does cause loss of an automatic diagnostic and is not detected by another diagnostic.
Fail Annunciation Detected	Failure that does not cause a false trip or prevent the safety function but does cause loss of an automatic diagnostic or false diagnostic indication.
Fail No Effect	Failure of a component that is part of the safety function but that has no effect on the safety function.
Low demand mode	Mode, where the frequency of demands for operation made on a safety-related system is no greater than twice the proof test frequency.

1.2 Acronyms

FMEDA	Failure Modes, Effects and Diagnostic Analysis
HFT	Hardware Fault Tolerance
MOC	Management of Change. These are specific procedures often done when performing any work activities in compliance with government regulatory authorities.
PFDavg	Average Probability of Failure on Demand
SFF	Safe Failure Fraction, the fraction of the overall failure rate of a device that results in either a safe fault or a diagnosed unsafe fault.
SIF	Safety Instrumented Function, a set of equipment intended to reduce the risk due to a specific hazard (a safety loop).
SIL	Safety Integrity Level, discrete level (one out of a possible four) for specifying the safety integrity requirements of the safety functions to be allocated to the E/E/PE safety-related systems where Safety Integrity Level 4 has the highest level of safety integrity and Safety Integrity Level 1 has the lowest.
SIS	Safety Instrumented System – Implementation of one or more Safety Instrumented Functions. A SIS is composed of any combination of sensor(s), logic solver(s), and final element(s).

1.3 Product Support

Technical and sales information as well as support about the Trimod Besta level switch can be obtained from:

Besta AG	Phone +41 43 399 15 15
Ackerstrasse 45	Fax +41 43 399 15 00
CH-8610 Uster	info@besta.ch
Switzerland	www.besta.ch

1.4 Related Literature

Hardware Documents:

- Before installation of Trimod Besta level switch see the operating instruction supplied with the product. Follow these instructions carefully for safety reasons.

Guidelines/References:

- Safety Integrity Level Selection – Systematic Methods Including Layer of Protection Analysis, ISBN 1-55617-777-1, ISA
- Control System Safety Evaluation and Reliability, 2nd Edition, ISBN 1-55617-638-8, ISA
- Safety Instrumented Systems Verification, Practical Probabilistic Calculations, ISBN 1-55617-909-9, ISA

1.5 Reference Standards

Functional Safety

- IEC 61508: 2010 Functional safety of electrical/electronic/ programmable electronic safety-related systems
- ANSI/ISA 84.00.01-2004 (IEC 61511 Mod.) Functional Safety – Safety Instrumented Systems for the Process Industry Sector

2 Product Description

The Trimod Besta level switch is a reliable and ideal solution for switching levels for many different applications in ship-, power-, oil and gas-, chemical-, food-, water- and plant-industry. With the 3 modular concept the Trimod Besta level switch can be configured for countless applications.

Each Trimod Besta level switch consists of 3 modules.

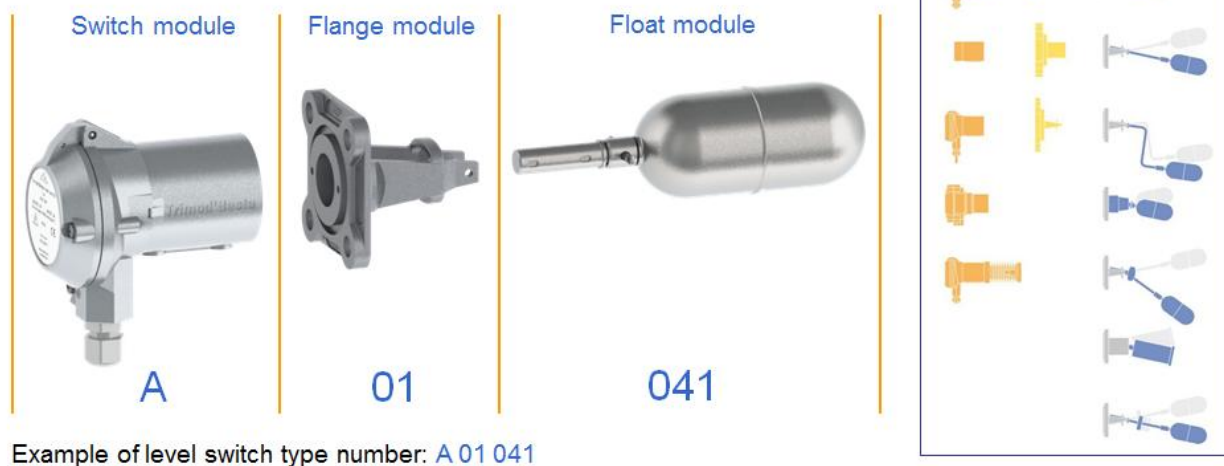

The switching module can be replaced without removing the flange or opening and draining the tank. The double snap action guarantees stable and oscillation free switching function.

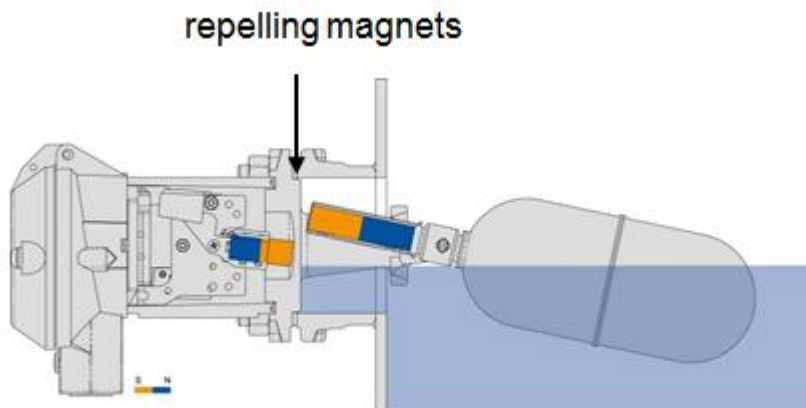

All Trimod Besta level switches operate on a magnetic principle. Two permanent magnets operate the switching movement, acting through the flange wall, which seals the wet side from the switch housing. The rising liquid level moves the float with its magnet. The second magnet is moved by repelling force and switching takes place by snap action of the micro switch, which can be installed in single or double configuration. Silver-, gold plated-, ex proof- micro switches and proximity switches are available. SIL 2 level is available by the double switch configuration.

3 Application Examples

Alarm, limit and control functions with Trimod Besta

Limiting maximum/minimum

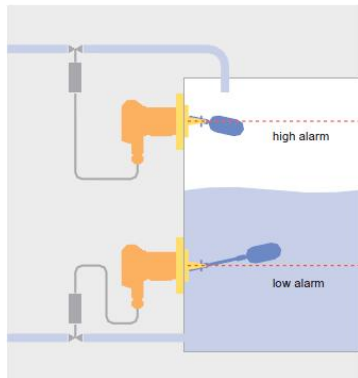

Open loop control for valves pumps and valves

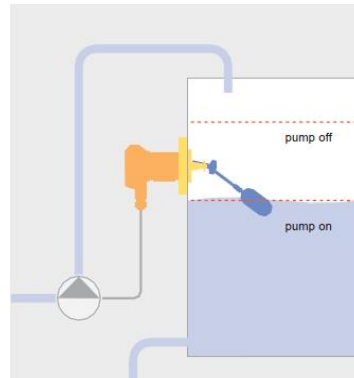

Open loop control for valves pumps and valves

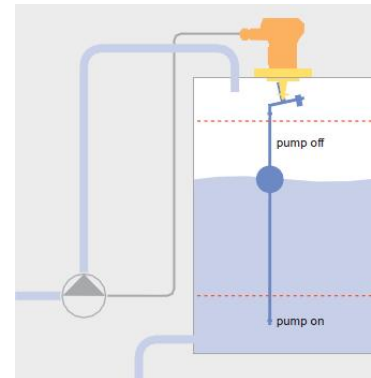

Limitation of separation layers

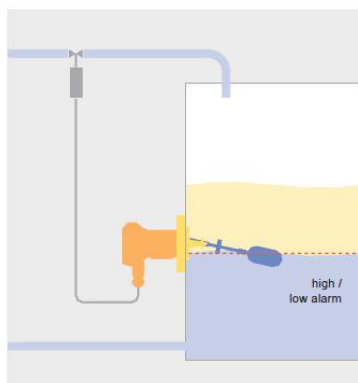

External fill level mounting

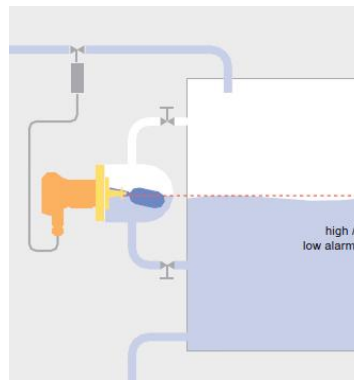

4 Available Certificates

- American Bureau of Shipping / ABS
- Bureau Veritas, Paris / BV
- China Classification Society / CCS
- Det Norske Veritas, Oslo / DNV
- Germanischer Lloyd, Hamburg / GL
- Lloyds Register of Shipping / LRS
- Registro Italiano Navale, Roma / R.I.N.A
- Russian Maritime Register of Shipping / RMRS
- Physikalisch-Technische Bundesanstalt / ATEX
- Bureau Veritas, Germany / ATEX
- International Electrotechnical Commission / IECEx
- Technischer Überwachungs-Verein / TÜV / PED
- GostR / GostR Ex
- Rostechnadzor / RTN

5 Ordering Information

Trimod Besta level switch models mentioned on page 9 – 11 of this manual were checked, assessed and certified by exida Certification S.A. meeting the IEC 61508 or IEC 61511 functional safety standards.

Our company has been checked, assessed and certified by exida Certification S.A.. Trimod Besta level switches are rated SIL 3 capable.

Besta SIL level information can be downloaded from our homepage.
(<http://www.besta.ch/en/downloads/approvals/sil.html>)

Note:

For all product information and downloads, visit www.besta.ch or send an inquiry to info@besta.ch

6 Designing a SIF using a Trimod Besta level switch

6.1 Safety Function

The Trimod Besta level switch will actuate a switched signal for either a high or low limit fluid level. The Trimod Besta level switch is intended to be part of final element subsystem as defined per IEC 61508 and the achieved SIL level of the designed function must be verified by the designer.

6.2 Environmental Limits

The designer of a SIF must check that the Trimod Besta level switch is rated for use within the expected environmental limits. Refer to chapter 4 of the Trimod Besta level switch operating instruction for environmental limits.

6.3 Application Limits

The materials of construction of a Trimod Besta level switch are specified in the Trimod Besta level switch catalogue LTKxx1111_TMB.... It is especially important that the designer check for material compatibility considering on-site chemical contaminants. If the Trimod Besta level switch is used outside of the application limits or with incompatible materials, the reliability data provided becomes invalid.

6.4 Design Verification

A detailed Failure Mode, Effects, and Diagnostics Analysis (FMEDA) report is available from Besta AG. This report details all failure rates and failure modes as well as the expected lifetime.

The achieved Safety Integrity Level (SIL) of an entire Safety Instrumented Function (SIF) design must be verified by the designer via a calculation of PFD_{AVG} considering architecture, proof test interval, proof test effectiveness, any automatic diagnostics, average repair time and the specific failure rates of all products included in the SIF. Each subsystem must be checked to assure compliance with minimum hardware fault tolerance (HFT) requirements. The exida exSILentia® tool is recommended for this purpose as it contains accurate models for the Trimod Besta level switch and their failure rates.

When using a Trimod Besta level switch in a redundant configuration, a common cause factor of at least 5% should be included in safety integrity calculations.

The failure rate data listed in the FMEDA report is only valid for the useful life time of a Trimod Besta level switch. The failure rates will increase sometime after this time period. Reliability calculations based on the data listed in the FMEDA report for mission times beyond the lifetime may yield results that are too optimistic, i.e. the calculated Safety Integrity Level will not be achieved.

6.5 SIL Capability

6.5.1 Systematic Integrity

The Trimod Besta level switch has met manufacturer design process requirements of Safety Integrity Level (SIL) 3. These are intended to achieve sufficient integrity against systematic errors of design by the manufacturer.

6.5.2 Random Integrity

When the final element assembly consists of many components (Trimod Besta level switch, SIS logic solver, actuator, solenoid, valve, etc.) the SIL must be verified for the entire assembly using failure rates from all components. This analysis must account for any hardware fault tolerance and architecture constraints.

6.5.3 Safety Parameters

For more details about the calculated failure rate refer to the Failure Modes, Effects and Diagnostic Analysis Report for the Trimod Besta level switch.

Failure rates per IEC 61508:2010

	[V1]	[V2]	[V3]	[V4]	[V5]	[V6]	[V7]
λ_{Safe}	81	157	20	35	81	157	76
λ_{DD}^3	0	136	0	20	0	136	0
λ_{DU}	139	71	97	87	161	93	128
No effect	131	142	123	133	140	151	88
No part	50	50	50	50	50	50	50
λ_{AU}^4	0	8	0	1	0	8	0
λ_{Total}	220	364	117	142	242	386	204
SFF	36%	80%	16%	38%	33%	75%	37%
SIL AC ⁵	SIL1	SIL2	SIL1	SIL1	SIL1	SIL2	SIL1

Overview of the considered switch modules

[V1]	<p>A, B, DA, DB, XA, XB, ZK 2A, 2B, 2DA, 2DB, X2A, X2B, U..A, U..B, XU..A, XU..B, Z2K, ZU..K 5A, 5B, 5DA, 5DB, X5A, X5B, 5U..A, 5U..B, X5U..A, X5U..B, Z5K, Z5U..K Modules with cable glands: 10 = Marine Standard W, 30 = Marine Standard Z Modules with threads: 40 = Aluminium 3/4"NPT, 54 = Stainless steel 3/4" NPT 42 = Aluminium chromated 3/4" NPT Available Ex-approvals: 1 = GOST-R Ex, 3 = INMETRO, 5 = IECEX, 8 = ATEX Ship registers: ABS, BV, CCS, DNV, GL, LR, RINA, RMRS Exxx/SPECxxx = customized production</p>
[V2]	<p>AA, BB, DAA, DBB, XAA, XBB, ZKK, 2AA, 2BB, 2DAA, 2DBB, X2AA, X2BB, XU..AA, XU..BB, Z2KK, ZU..KK 5AA, 5BB, 5DAA, 5DBB, X5AA, X5BB, X5U..AA, X5U..BB, Z5KK, Z5U..KK Modules with cable glands: 10 = Marine Standard W, 30 = Marine Standard Z Modules with threads: 40 = Aluminium 3/4"NPT, 54 = Stainless steel 3/4" NPT 42 = Aluminium chromated 3/4" NPT Available Ex-approvals: 1 = GOST-R Ex, 3 = INMETRO, 5 = IECEX, 8 = ATEX Ship registers: ABS, BV, CCS, DNV, GL, LR, RINA, RMRS Exxx/SPECxxx = customized production</p>
[V3]	<p>I, IN, IE9, INE9, DI, DIN, DIE9, DINE9, XI, XIN, XIE9, XINE9 2I, 2IN, 2IE9, 2INE9, 2DI, 2DIN, 2DIE9, 2DINE9, HI, HIN, HIE9, HINE9, TDI, TDIN, TDIE9, TDINE9 5I, 5IN, 5IE9, 5INE9, 5DI, 5DIN, 5DIE9, 5DINE9, 5HI, 5HIN, 5HIE9, 5HINE9, 5TDI, 5TDIN, 5TDIE9, 5TDINE9 Modules with cable glands: 10 = Marine Standard W, 30 = Marine Standard Z Modules with threads: 40 = Aluminium 3/4"NPT, 54 = Stainless steel 3/4" NPT 42 = Aluminium chromated 3/4" NPT Available Ex-approvals: 1 = GOST-R Ex, 3 = INMETRO, 5 = IECEX, 8 = ATEX Ship registers: ABS, BV, CCS, DNV, GL, LR, RINA, RMRS Exxx/SPECxxx = customized production</p>
[V4]	<p>II, IIE9, DII, DIIE9, XII, XIIE9, 2II, 2IIE9, 2DII, 2DIIE9, X2II, X2IIE9, HII, HIIE9, TDII, TDIIIE9 5II, 5IIE9, 5DII, 5DIIE9, X5II, X5IIE9, 5HII, 5HIIE9, 5TDII, 5TDIIIE9 Modules with cable glands: 10 = Marine Standard W, 30 = Marine Standard Z Modules with threads: 40 = Aluminium 3/4"NPT, 54 = Stainless steel 3/4" NPT 42 = Aluminium chromated 3/4" NPT Available Ex-approvals: 1 = GOST-R Ex, 3 = INMETRO, 5 = IECEX, 8 = ATEX Ship registers: ABS, BV, CCS, DNV, GL, LR, RINA, RMRS Exxx/SPECxxx = customized production</p>
[V5]	<p>HA, HB, ZHK, TDA, TDB, ZTDK 5HA, 5HB, 5TDA, 5TDB, Z5HK, Z5TDK Modules with cable glands: 10 = Marine Standard W, 30 = Marine Standard Z Modules with threads: 40 = Aluminium chromated 3/4"NPT, 54 = Stainless steel 3/4" NPT Available Ex-approvals: 1 = GOST-R Ex, 3 = INMETRO, 5 = IECEX, 8 = ATEX Ship registers: ABS, BV, CCS, DNV, GL, LR, RINA, RMRS Exxx/SPECxxx = customized production</p>
[V6]	<p>HAA, HBB, ZHKK, TDAA, TDBB, ZTDKK 5HAA, 5HBB, 5TDAA, 5TDBB, Z5HKK, Z5TDKK Modules with cable glands: 10 = Marine Standard W, 30 = Marine Standard Z Modules with threads: 40 = Aluminium chromated 3/4"NPT, 54 = Stainless steel 3/4" NPT Available Ex-approvals: 1 = GOST-R Ex, 3 = INMETRO, 5 = IECEX, 8 = ATEX Ship registers: ABS, BV, CCS, DNV, GL, LR, RINA, RMRS Exxx/SPECxxx = customized production</p>
[V7]	<p>C 01C 05, DC 01C 05, C 329C 05, DC 329C 05 Exxx/SPECxxx = customized production</p>

All the above mentioned models except [V7] can be combined with the following flange and float modules:

Trimod Besta Flange Modules

Flange modules: Standard: 01, 011, 0118
Special: 03, 04, 06, 038, 048, 068
Industry: DIN, ANSI, BS, JIS
Fix- and composite flange modules
Bracket lengths: F = 68mm, L/Z = 102mm, S/Y = 142mm
Sealing units made of: 1.4571, 8 = Hastelloy, N = Nace
Slip-on flanges made of: H II, 13 CrMo 44, A 350-LF2
Exxx/SPECxxx = customized production
Available standards: P = PED

Trimod Besta Float Modules

Float modules: 01, 02, 03, 04, 041, 07, 26, 27, 031, 032, 76
011, 012, 013, 051, 052, 053, 054, 071, 072, 073, 074, 761, 762, 763, 764
090, 091, 092, 093, 095, 140, 141, 142, 145, 146
08T1, 28T1, 081T1, 082T1, 083T1, 084T1
G1, H1, G2, H2, G3, H3, G5
Exxx/SPECxxx = customized production
Made of: 1.4571, 4xx = Hastelloy, N = Nace
Available standards: P = PED

6.6 Connection of the Trimod Besta level switch to the SIS Logic-solver

The Trimod Besta level switches are connected to the safety rated logic solver which is actively performing the safety function.

6.7 General Requirements

The system's response time shall be less than process safety time. The Trimod Besta level switch will move to its safe state in less than the process safety time under specified conditions.

All SIS components including the Trimod Besta level switch must be operational before process start-up.

User shall verify that the Trimod Besta level switches are suitable for use in safety applications by confirming the Trimod Besta level switch nameplates are properly marked.

Personnel performing maintenance and testing on the Trimod Besta level switch shall be competent to do so.

Results from the proof tests shall be recorded and reviewed periodically.

The useful life of the Trimod Besta level switch is discussed in the Failure Modes, Effects and Diagnostic Analysis Report for the Trimod Besta level switch.

7 Installation and Maintenance

7.1 Installation and Commissioning

The Trimod Besta level switch must be installed and set into service as per Besta operating instruction delivered with the product or available upon request.

The environment must be checked to verify that environmental conditions do not exceed the ratings under chapter 4.

The Trimod Besta level switch must be accessible for physical inspection.

7.2 Physical Location and Placement

The Trimod Besta level switch shall be accessible with sufficient room for, and shall allow manual proof testing.

If the float is not accessible during operation, Besta offers various test devices. Besta switches can be tested during operation with the appropriate test device.

The Trimod Besta level switch shall be mounted in a low vibration environment. If excessive vibration can be expected special precautions shall be taken to ensure the integrity of connectors or the vibration should be reduced using appropriate damping mounts.

8 Operation and Maintenance

8.1 Proof Test without automatic testing

The objective of proof testing is to detect failures within that are not detected by any automatic diagnostics of the system. Of main concern are undetected failures that prevent the safety instrumented function from performing its intended function.

The frequency of proof testing, or the proof test interval, is to be determined in reliability calculations for the safety instrumented functions for which a Trimod Besta level switch is applied. The proof tests must be performed more frequently than or as frequently as specified in the calculation in order to maintain the required safety integrity of the safety instrumented function.

The following proof test is recommended. The results of the proof test should be recorded and any failures that are detected and that compromise functional safety should be reported to Besta AG. The suggested proof test consists of a full stroke of the Trimod Besta level switch.

Step	Action
1	Bypass the safety PLC or take other appropriate action to avoid a false trip
2	Inspect the device for any visible damage, corrosion or contamination.
3	Force the device to reach a defined "MAX" threshold value and verify that the output goes into the safe state.
4	Force the device to reach a defined "MIN" threshold value and verify that the output goes into the safe state.
5	Restore the loop to full operation

Table1: Recommended Proof Test

It is assumed that this test achieves a proof test coverage (PTC) of at least 90%.

The person(s) performing the proof test of a Trimod Besta level switch should be trained in SIS operations, including bypass procedures, switch maintenance and company management of change procedures. No special tools are required.

Besta offers test devices if the float is not accessible during operation. Besta switches can be tested during operation with the appropriate test actuator.

8.2 Repair and Replacement

Repair procedures in the Trimod Besta level switch operation manual must be followed.

8.3 Useful Life

The useful lifetime used in the FMEDA calculations is 10 years although the practical lifetime is normally considerably longer – typically 15 years.

8.4 Besta AG Notification

Any failures that are detected and that compromise functional safety should be reported to Besta AG. Please contact Besta AG customer service.